

4-WHEEL WASTE AND RECYCLABLES CONTAINERS

1100 L SPLIT LID

BE CLEVER BE FLEXIBLE!

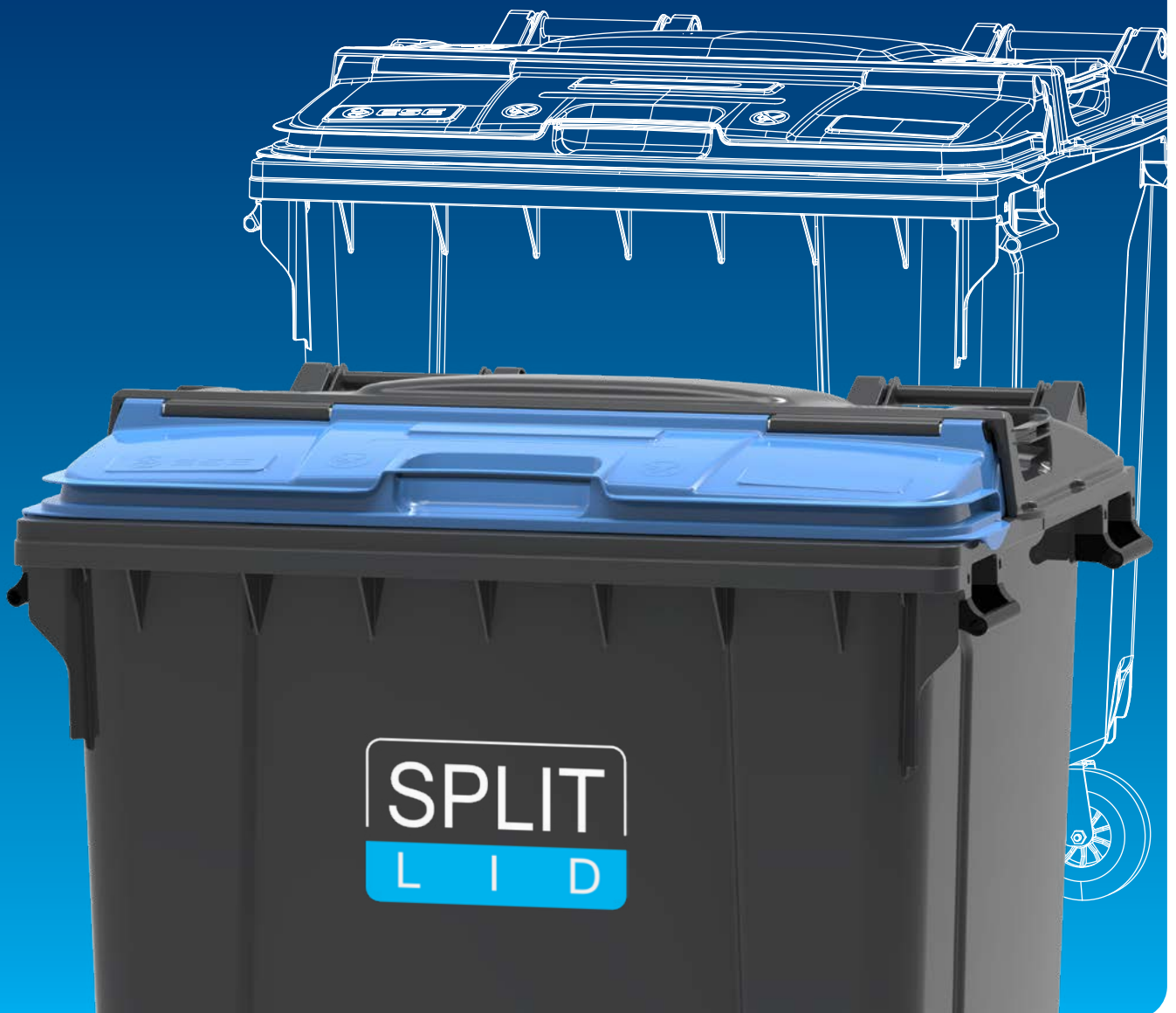

FROM THE IDEA TO THE PRODUCT

THE CHALLENGE

The number of 1100 litre waste and recyclables containers in the municipal and public domain has increased substantially in recent years. There are 2 types: bins with sliding or round lids and bins with flat lids. Under certain conditions, flat-lid bins can encounter problems with rotating-drum vehicles because of their long, wide lids. In a few cases, collisions can even occur between lids and waste residues in the tipping zone or with compactor plates. Such contact problems do not usually arise with round-lid bins, but these are more costly and maintenance-intensive than flat-lid bins. Also, the trucks need to be equipped with a special lid-opener in the lifting device.

THE IDEA

The idea was to combine the advantages of round-lid bins with those of flat-lid bins: to develop a flat-lid bin that could be emptied without difficulty by any vehicle, but would possess all the ergonomic advantages of a round-lid bin with lid-in-lid system.

THE REQUIREMENTS

The solution would be a split lid, consisting of a base lid and a flexible front lid. Features such as long-life hinges, easily replaceable front lid, no ingress of rain or snowmelt into the bin and retrofitability on existing bins were conditions that had to be met without exception.

DEVELOPMENT

Apart from the technical modifications, many other factors were taken into account at the same time in the development process. A new product must be stylish, ergonomic, functional and of high quality to carry conviction on the market and set new standards. That is our ambition and we aim to achieve it!

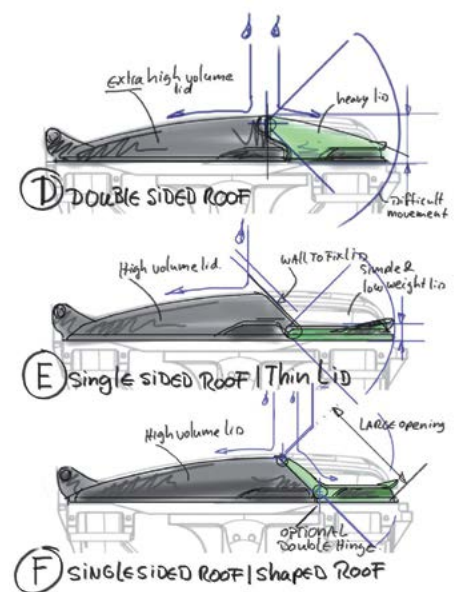
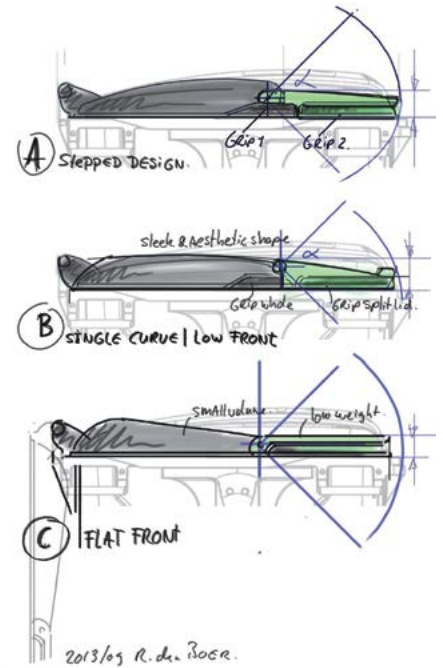

SPLIT LID

UNBEATABLY PRACTICAL

The result is worth looking at! The Split Lid combines safety, ease of handling and economy, and is an interesting alternative to bins with round lids.

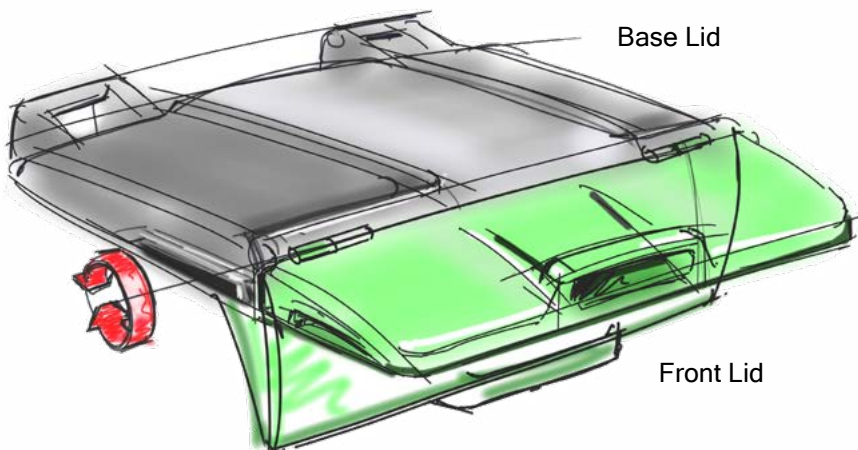
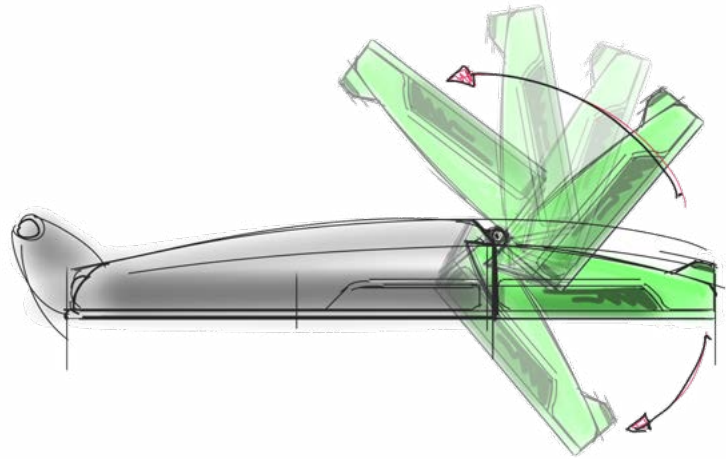

The integral bow-type handle in the middle of the front lid combined with a lip handle all round the edge is a unique solution. The front lid can be opened 150° and remains in that position during filling. The base lid section of the split lid can easily be opened completely using the bow-type handles at the sides. From neutral position, the front lid can also swing downwards, so that it can yield to any contact zones in the refuse truck during emptying.

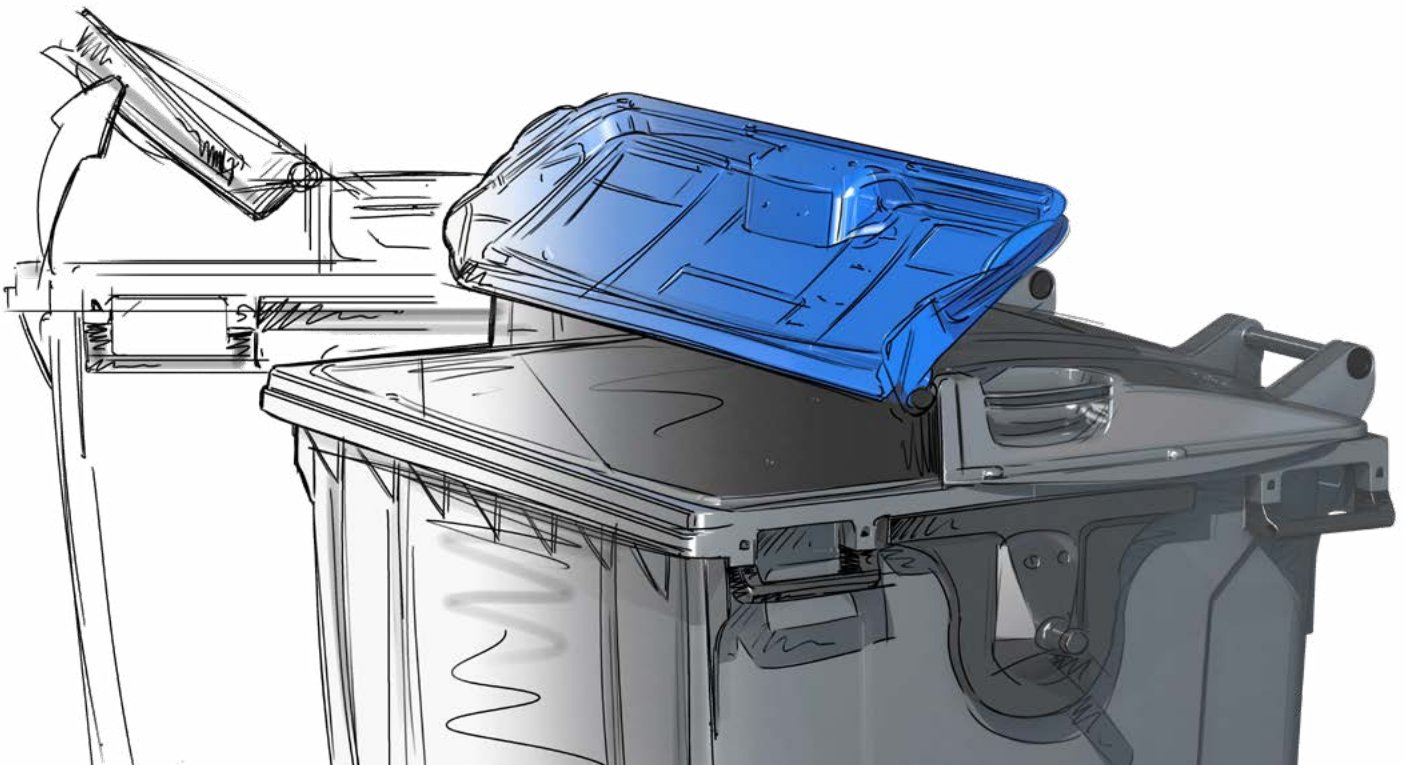

SPLIT LID

DOUBLE ADVANTAGE

BE CLEVER, BE FLEXIBLE!

In practical use, the lids of 1100 litre containers frequently collide with the compression mechanism of collection vehicles. Residual waste in the hopper can also come into contact with lids. The consequence is often damage to lids and hinges.

The Split Lid, with its flexible front element which can hinge in either direction, is at a significant advantage here: it simply gives way, in either direction! Fracture of the lid or damage to the body hinge is practically impossible. All in all, it significantly reduces the risk of accidents due to damaged bins.



Contact with waste in the loading hopper



Contact with compactor plate



Split Lid video animation

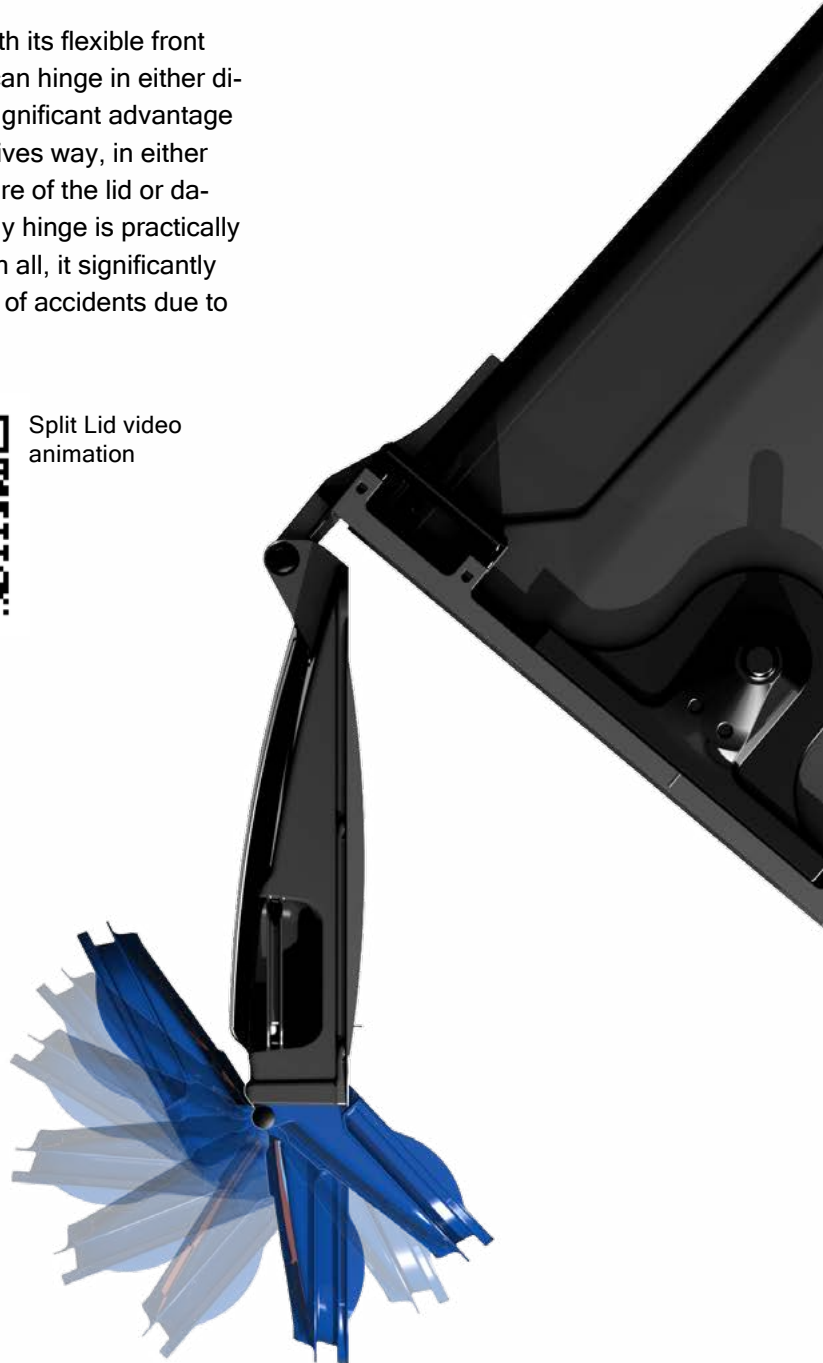



REPLACED IN NO TIME!

All lid components are designed to be easily fitted and replaced. Like the standard flat lid, the whole lid is fitted using the same lid bolts. Thus any ESE 1100-litre flat-lid bin can be retrofitted with the new Split Lid. For changes of fraction, only the front lid of a bin needs to be replaced with a different-coloured one. For this reason, all applicable marking devices are located only on the front lid. This makes storage more efficient, and hence more economical.

INTELLIGENT COLOUR CONCEPT

The ESE Colour Concept is based on a simple equation: less colour = more recycling. This is embodied in the use of uniform dark-grey basic containers with coloured front lids for fraction identification. Not only is it more attractive to look at - the new Split Lid combines technical and economic advantages with a better Life-Cycle Assessment.

All 1100 L bins are available with the Blue Angel environmental label because they are made from recycled materials (RAL-UZ 30a).

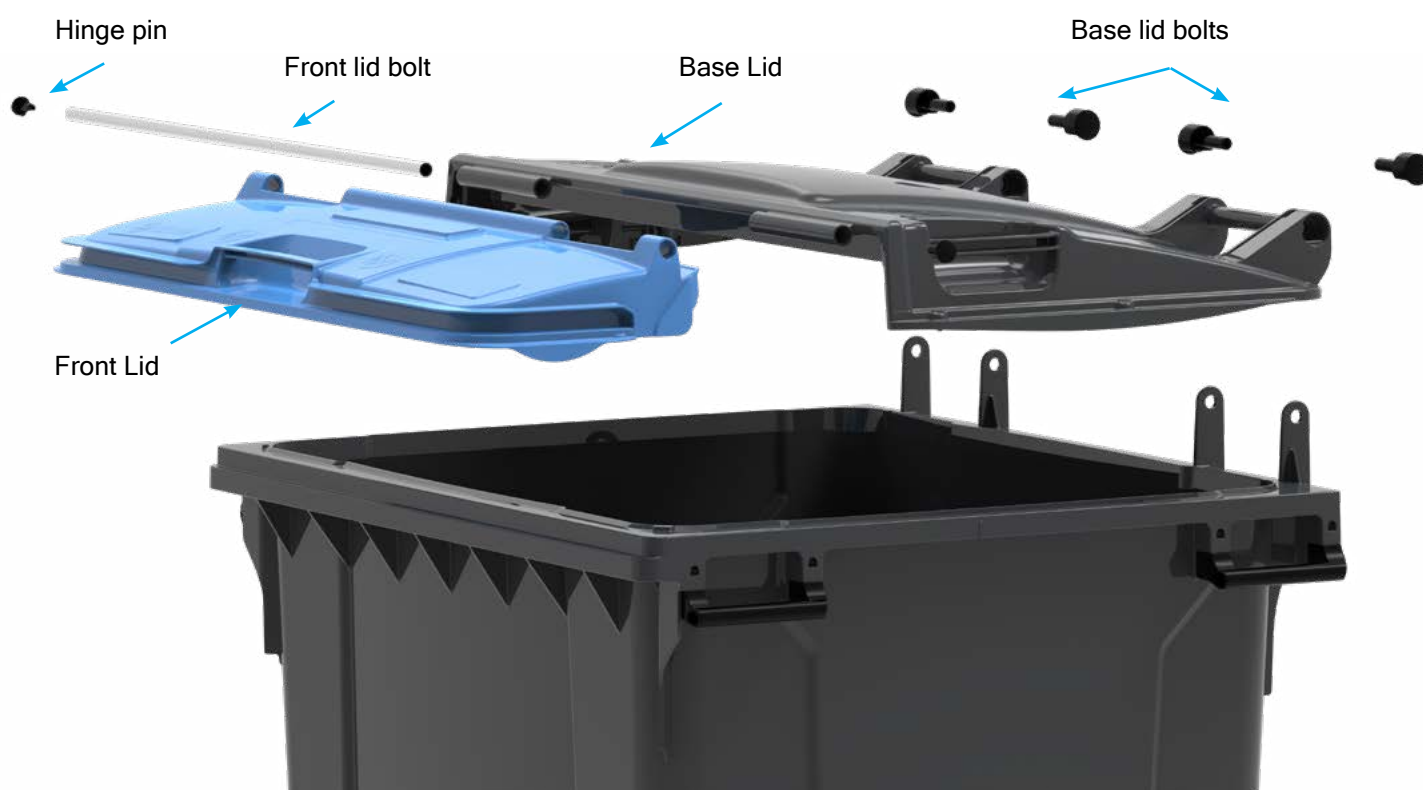

ERGONOMIC, PRACTICAL AND GOOD

ERGONOMICALLY DESIGNED

The front lid is very light compared to the complete lid. With its central open handgrip in the middle and the additional lip handle all round the edge, it can be opened easily, even by children, the elderly or people with a disability. It can be completely opened without difficulty, so that it can be filled with one hand. This is especially convenient when there are several waste bags to be disposed of. It is not essential to open the whole lid, which house walls often render impossible except by moving the bin.

LESS EFFORT

The ergonomic improvements mean that it takes around 60% less effort to open the front lid. Because it is now easier to fill the bin, problems of bin lids being left open are significantly fewer.

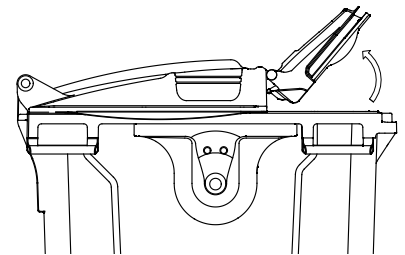

Effort required to open the lid approx. 1,3 kg

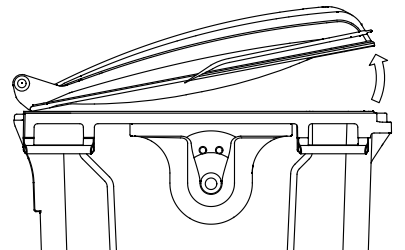

Effort required to open the lid approx. 3,4 kg



Open handle

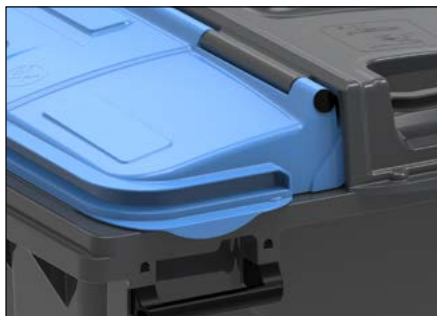

Peripheral handle convenient for handi-capped users

LESS NOISE

The front lid can also be fitted with noise reducers - but even without this option, it is significantly quieter than a full lid.



Noise reducers on front lid

WELL THOUGHT-OF

The lateral handle makes the lid easy for wheelchair users to operate. For this purpose, access must be provided at the side of the bin.





COMPREHENSIVE STANDARD

- Reinforced body construction, ribbed front and rear walls
- Base structure and high stress areas are computer-designed and tested for durability
- Lids have a side lip for automatic closing and positioning when on uneven ground, irrespective of ground surface type
- Wide symmetrical lifting trunnions with reinforcement tubes
- Strong integrated lid bolts
- Four ergonomic handles on the side as standard (handles are exchangeable)
- DIN comb receiver with honeycomb ribbing
- Centrally positioned water drain plug secured against dropping
- Reinforced wheel housings
- Rounded corners at the base
- Smooth surfaces for easy Maintenance
- Eight ribs in the chip-nest secure the position of the transponder
- Colours: 16 standard colours; additional colours on request
- Certificate: Blue Angel Eco Label



FUNCTIONAL AND CONFORMING TO STANDARDS

ESE always considers the entire logistic and application chain when designing products. Requirements for filling, emptying, handling and health and safety are perfectly harmonized.

The containers fulfil all European and national standards currently in force and are certified according to the technical test specifications of EN 840 and the world's highest quality standard, RAL-GZ 951/1.



OPTIONS

- Choice of locking devices
- Noise reduction
- Direction lock
- Central brake system
- Heavy duty wheels
- Towing device
- Fork lift pockets
- Identification systems

DIMENSIONS

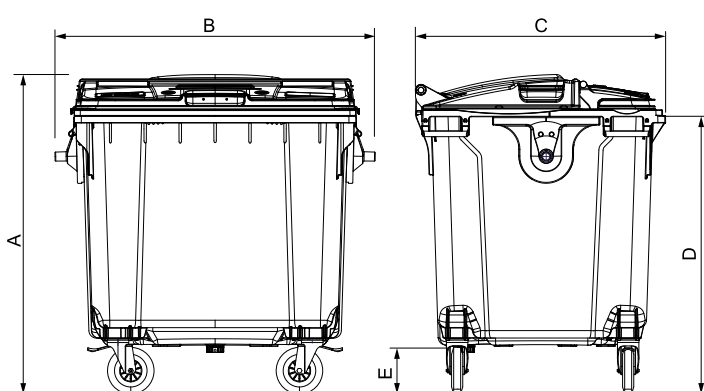

TECHNISCHE DATEN

Nominal volume (l)	1100
Weight of container (kg)	50
Max. permissible weight (kg)	510
A Overall height (mm)	1370
B Overall width (mm)	1375
C Overall depth (mm)	1075
D Height to upper edge of comb (mm)	1220
E Wheel diameter	200

These details are subject to technical changes. For further options, please refer to our accessories brochure. The products contain no substances on the SVHC list of the European Chemicals Agency (ECHA).

ESE - WE VALUE YOUR RECYCLABLES



KERBSIDE SYSTEMS
MOBILE CONTAINERS FOR
WASTE AND RECYCLABLES



BRING SYSTEMS
(SEMI-) UNDERGROUND SYSTEMS
COLLECTION BANKS



BIO SELECT LINE
CONTAINERS AND COMPOSTERS
FOR GARDEN AND BIO WASTE



HAZARDOUS WASTE CONTAINERS
MOBILE FUEL CONTAINERS
MOBILE OIL CHANGE UNITS



PUBLIC FURNISHING
BINS FOR THE PUBLIC SPACE



CONTAINER MANAGEMENT
DISTRIBUTION, REGISTRATION,
COLLECTION AND RECYCLING

ESE is Europe's leading manufacturer of temporary storage solutions for waste and recyclables. Our comprehensive range of products is complemented by a full service offer from container management to the recycling of products at the end of their lifetime. Specialists in all departments develop solutions to meet our customers' requirements. In doing so, we follow the principle of highest possible sustainability from product development and production to transport.